

押締端子盤



Press-to-screw Terminal Block

ピッチ/Pitch 5.08mm

型名 Type Number	F6203
定格 Rating	AC250V 8 A
絶縁抵抗 Insulation Resistance	500V 1000MΩ 以上 DC500V 1000MΩ and over
耐電圧 Withstands Voltage	2000V 1 分間以上 AC2000V 1 minute and over
適合電線 Compatible Wire	本文を御参照下さい Refer to the text

一般公差/General Tolerance ±0.5

尺度/Scale 1/1 単位/Unit mm

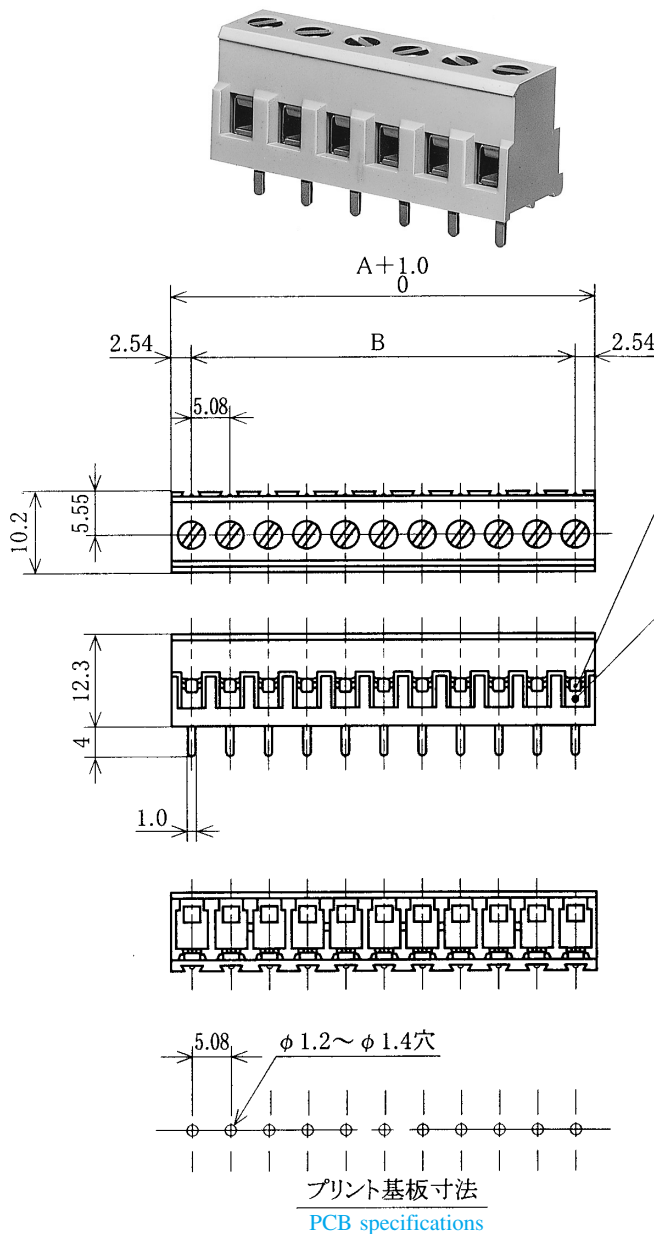

導通チェッカー部/Checking port for continuity test

電線差し込み口/Wire insertion port

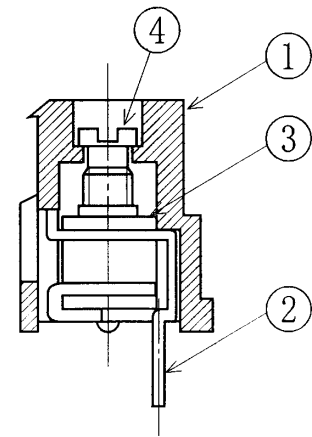

押
締
端
子
盤

- 注文方法：[型名] — [極数] P.
- Ordering Form : Type No. No. of Poles (P)
- 結線ビス：締付トルクは0.5N・mです。(保証値)
- Connection screw : Tightening torque is 0.5 N・m (Guaranteed level)
- 電線の接続、解除はマイナスドライバーで行う。
- The wire should be connected and disconnected with a minus driver.
- 適合電線：0.128~0.81mm² (より線)、φ0.4~1.0 (単線)
- Compatible wire : 0.128~0.81 mm² (Stranded wire), φ0.4~φ1.0 (Solid wire)
- 線むき長さ：5~7 mm
- Stripped wire length : 5~7 mm

仕様/Specifications.

部番/Part No.	名称/Part Name	材質/Material	規格/Standard	寸法/Size	処理/Treatment	備考/Remark
1	基板 Base	66ナイロン Nylon66	UL			グレー Gray
2	導電板 Terminal	黄銅 Brass	C2680R	板厚 t 0.6	スズメッキ Tin-Plated	
3	チューブコンタクト Tubular contact	りん青銅 Phosphor bronze	C5191R		ニッケルメッキ Nickel-Plated	
4	結線ビス Screw	鉄 Steel	SWCH	M2.5×0.45	ニッケルメッキ Nickel-Plated	平(頭)ビス Type⑨

極数/Poles	1P	2	3	4	5	6	7	8	9	10	11	12	13	14	15
A	5.08	10.16	15.24	20.32	25.40	30.48	35.56	40.64	45.72	50.80	55.88	60.96	66.04	71.12	76.20
B	—	5.08	10.16	15.24	20.32	25.40	30.48	35.56	40.64	45.72	50.80	55.88	60.96	66.04	71.12