

ピッチ/Pitch 8.7mm

型名 Type Number	F5205ABLT
定格 Rating	AC250V 8 A
絶縁抵抗 Insulation Resistance	500V 1000MΩ 以上 DC500V 1000MΩ and over
耐電圧 Withstands Voltage	2000V 1 分間以上 AC2000V 1 minute and over
接触抵抗 Connection Resistance	10mΩ 以下 10mΩ and less
適合電線 Compatible Wire	0.75mm ²
極数 Number of Poles	7 P

一般公差/General Tolerance ±0.5

尺度/Scale 1/1 単位/Unit mm

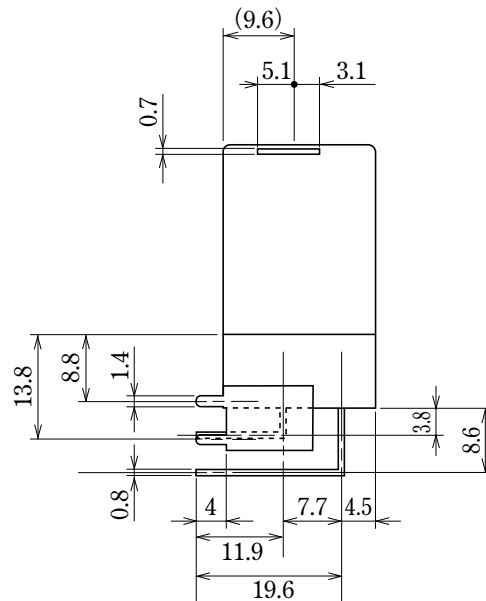
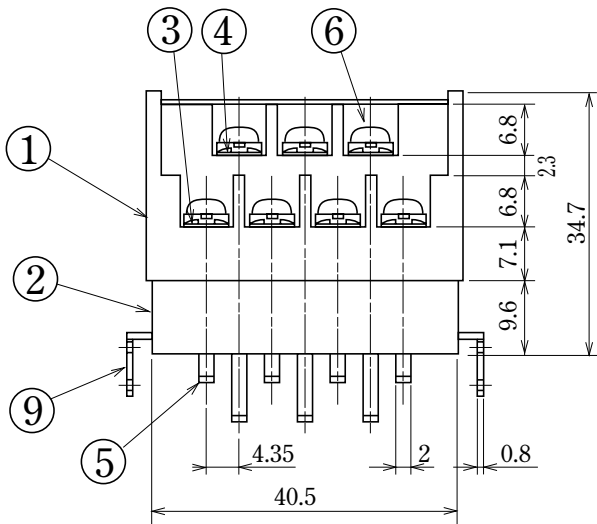
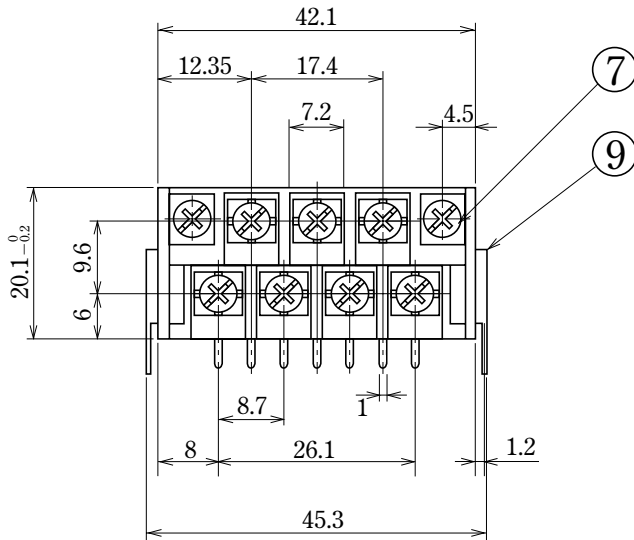

- 注文方法: 型名 7 P.
- Ordering Form: Type No. No. of Poles (P)
- 結線ビス: 締付トルクは1.0N・mです。
- Connection screw: Tightening torque is 1.0N・m.

仕様/Specifications.

部番/Part No.	名称/Part Name	材質/Material	規格/Standard	寸法/Size	処理/Treatment	備考/Remark
1	基板 A Base A	PBT	UL			黒色 Black
2	基板 B Base B	PBT	UL			黒色 Black
3	コンタクトA Contact A	りん青銅 Phosphor bronze	C5191R	板厚 t 0.3	ニッケルメッキ Nickel-Plated	コンタクト部金メッキ Contact point is plated with gold
4	コンタクトB Contact B	りん青銅 Phosphor bronze	C5191R	板厚 t 0.3	ニッケルメッキ Nickel-Plated	コンタクト部金メッキ Contact point is plated with gold
5	コンタクトC Contact C	黄銅 Brass	C2680R	板厚 t 0.8	金メッキ Gold-Plated	
6	結線ビス Screw	鉄 Steel	SWCH・SPCC	M3.5×0.6×7ℓ	ニッケルメッキ Nickel-Plated	フリータンシビス Type②
7	取付ビス Quick disconnct screw	鉄 Steel	SWCH	M3.5×0.6	ニッケルメッキ Nickel-Plated	
8	カバー Cover	ポリカーボネート Polycarbonate	UL	板厚 t 0.5		透明 Transparence
9	取付金具 Mt. metal fitting	黄銅 Brass	C2680R	板厚 t 0.8	スズメッキ Tin-Plated	