

型名 Type Number	F4074
定格 Rating	20A

一般公差 / General Tolerance ±0.5

尺度 / Scale 1/1 単位 / Unit mm

基板加工例
Processing the printed board

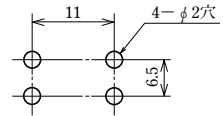

プリント基板厚 t 1.6~2.0
Printed board: t 1.6~2.0

- 注文方法：型番（下表の型番を御参照下さい）
- Ordering Form : Type No. (See the type number in the following table)

■仕様 / Specifications.

部番 / Part No.	名称 / Part Name	材質 / Material	寸法 / Size	規格 / Standard	処理 / Treatment
1	基板端子 Printed board terminal	黄銅 Brass	板厚 t 0.8	C2680R	スズメッキ Tin-Plated
2	結線ビス Screw	黄銅 Brass		C2700W	ニッケルメッキ Nickel-Plated

型番 / Type No.	納入される物 / Product Delivered
F4074C	基板端子 (M4用) のみ (ビスなし) / Printed board terminal (for M4) only (w/o screws)
F4074CS	基板端子+M4×6L バインドビス組付 / Printed board terminal+M4×6L binding head screw attached

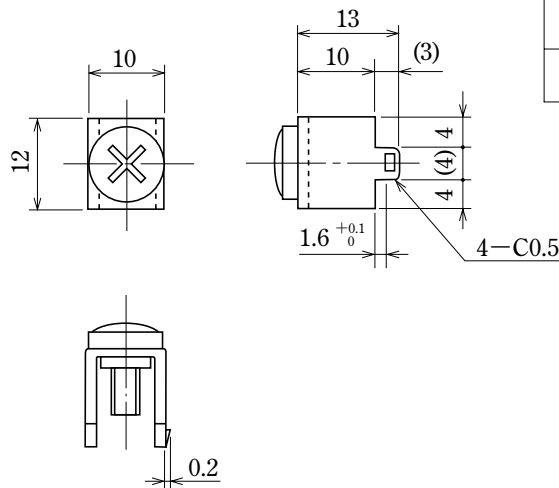
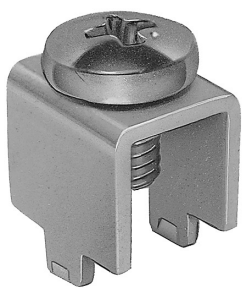

型名 Type Number	F4076
定格 Rating	40A

一般公差 / General Tolerance ±0.5

尺度 / Scale 1/1 単位 / Unit mm

基板加工例
Processing the printed board

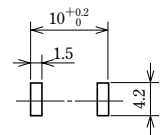

プリント基板厚 t 1.6~2.0
Printed board: t 1.6~2.0

- 注文方法：型番（下表の型番を御参照下さい）
- Ordering Form : Type No. (See the type number in the following table)

■仕様 / Specifications.

部番 / Part No.	名称 / Part Name	材質 / Material	寸法 / Size	規格 / Standard	処理 / Treatment
1	基板端子 Printed board terminal	黄銅 Brass	板厚 t 1.2	C2680R	スズメッキ Tin-Plated
2	結線ビス Screw	黄銅 Brass		C2700W	ニッケルメッキ Nickel-Plated

型番 / Type No.	納入される物 / Product Delivered
F4076D	基板端子 (M5用) のみ (ビスなし) / Printed board terminal (for M5) only (w/o screws)
F4076DS	基板端子+M5×8L バインドビス組付 / Printed board terminal+M5×8L binding head screw attached