

# 貫通型端子盤

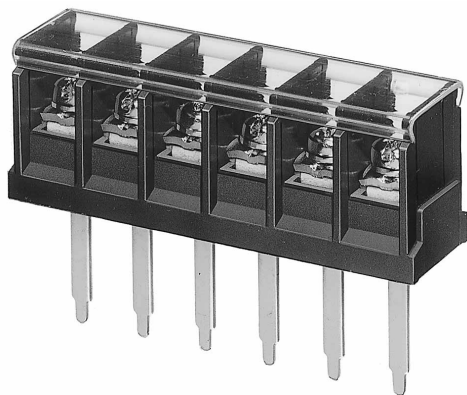

Through-type Terminal Block



ピッチ/Pitch 10mm

型名 Type Number	F2325AX
定格 Rating	AC250V 20A
絶縁抵抗 Insulation Resistance	500V 1000MΩ以上 DC500V 1000MΩ and over
耐電圧 Withstands Voltage	2000V 1分間以上 AC2000V 1 minute and over
適合電線 Compatible Wire	2.0mm <sup>2</sup>

一般公差/General Tolerance ±0.5

尺度/Scale 1/1 単位/Unit mm

貫通型

プリント基板用

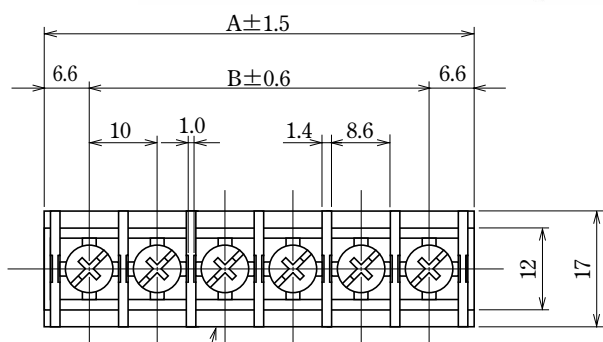

呼び/Nominal	L	D
4 L	4	4
8.6 L	8.6	3.6
12 L	12	3.6
13.5 L	13.5	4
20 L	20	3.6
28.5 L	28.5	3.6
55 L	54.8	10

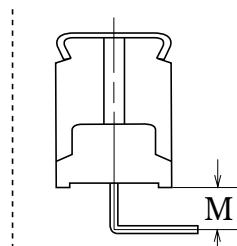

リード曲げ加工例  
Example of a lead bent

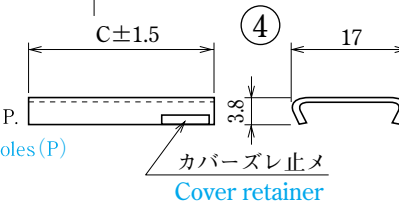
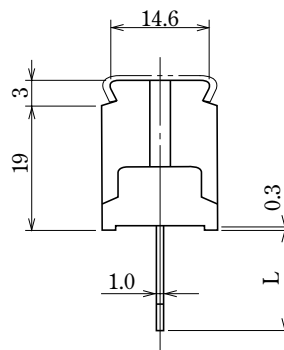
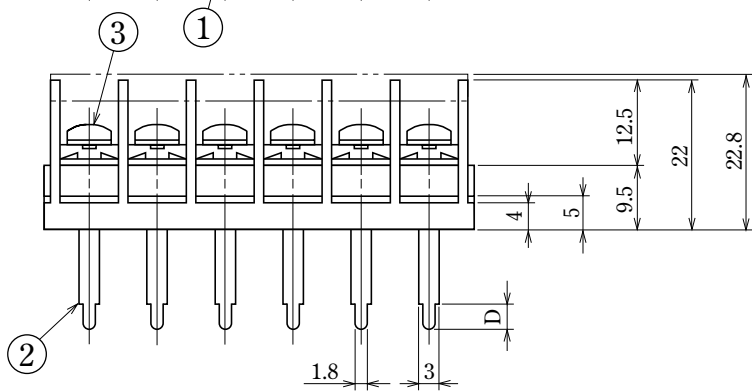

- 注文方法: 型名 — リード長 L — (曲げ希望時) 曲げ寸法 M — 極数 P.
- Ordering Form: Type No. — Lead Length (L) — Bent Length (M) (if bending is desired) — No. of Poles (P)

- 結線ビス: 締付トルクは1.4N・mです。
- Connection screw: Tightening torque is 1.4N・m.
- カバーはオプションとなっておりますので御希望の際は注文方法の末尾に“-CT”と御記入ください。但しカバーは添付納入となります。
- A cover is optional. To obtain one, add "-CT" to the end of the order description shown above. A cover will be delivered attached.

### 仕様/Specification.

部番/Part No.	名称/Part Name	材質/Material	規格/Standard	寸法/Size	処理/Treatment	備考/Remark
1	基板 Base	PBT	UL			黒色 Black
2	導電板 Terminal	黄銅 Brass	C2680R	板厚 t1.0	スズメッキ Tin-Plated	
3	結線ビス Screw	鉄 Steel	SWCH・SPCC	M4×0.7×8ℓ	ニッケルメッキ Nickel-Plated	フリータンシビス Type①
4	カバー Cover	ポリカーボネート Polycarbonate	UL	板厚 t0.8		透明 Transparence

極数/Poles	1P	2	3	4	5	6	7	8	9	10	11	12	13	14	15	16	17	18	19	20	21	22
A	13.2	23.2	33.2	43.2	53.2	63.2	73.2	83.2	93.2	103.2	113.2	123.2	133.2	143.2	153.2	163.2	173.2	183.2	193.2	203.2	213.2	223.2
B	—	10.0	20.0	30.0	40.0	50.0	60.0	70.0	80.0	90.0	100.0	110.0	120.0	130.0	140.0	150.0	160.0	170.0	180.0	190.0	200.0	210.0
C	11.6	21.6	31.6	41.6	51.6	61.6	71.6	81.6	91.6	101.6	111.6	121.6	131.6	141.6	151.6	161.6	171.6	181.6	191.6	201.6	211.6	221.6

極数/Poles	23	24
A	233.2	243.2
B	220.0	230.0
C	231.6	241.6