

貫通型端子盤



Through-type Terminal Block

ピッチ/Pitch 7.6mm



型名 Type Number	F2068NBX
定格 Rating	AC250V 10A
絶縁抵抗 Insulation Resistance	500V 1000MΩ以上 DC500V 1000MΩ and over
耐電圧 Withstands Voltage	2000V 1分間以上 AC2000V 1 minute and over
適合電線 Compatible Wire	0.75mm ²
極数 Number of Poles	2P

一般公差/General Tolerance ±0.5

尺度/Scale 1/1 単位/Unit mm

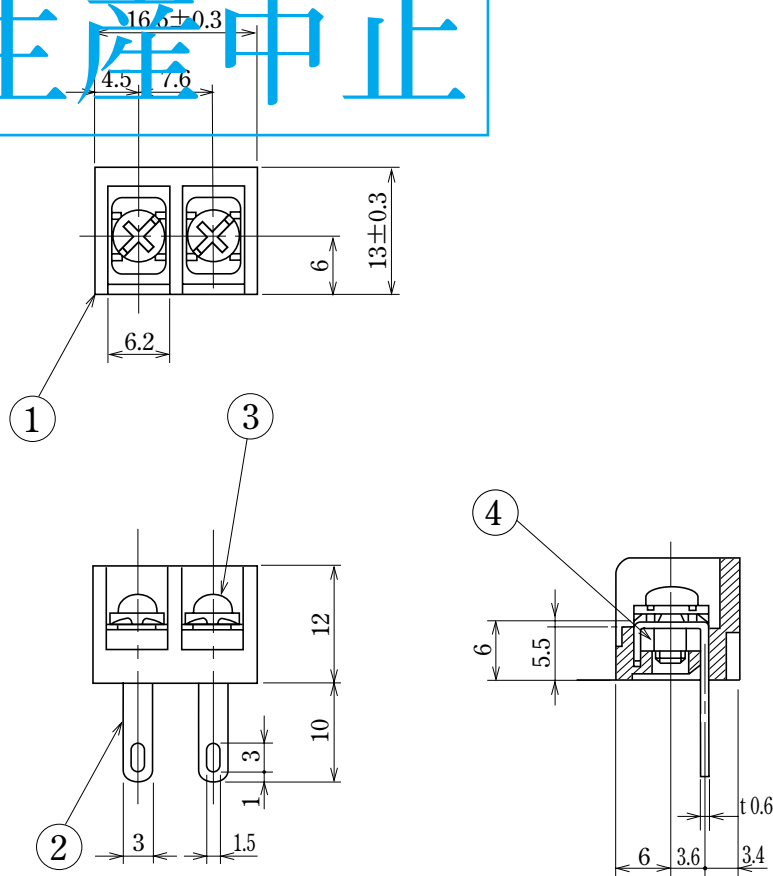
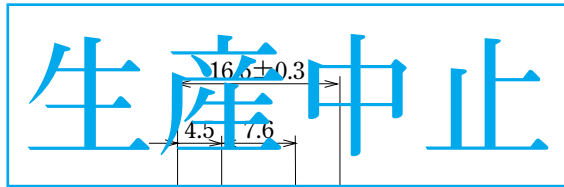

- 注文方法：型名 ———— 2 P.
- Ordering Form：Type No. No. of Poles (P)
- 結線ビス：締付トルクは0.6N・mです。
- Connection screw：Tightening torque is 0.6N・m.

■仕様/Specification.

部番/Part No.	名称/Part Name	材質/Material	規格/Standard	寸法/Size	処理/Treatment	備考/Remark
1	基板 Base	PBT	UL			黒色 Black
2	導電板 Terminal	黄銅 Brass	C2680R	板厚 t0.6	スズメッキ Tin-Plated	
3	結線ビス Screw	鉄 Steel	SWCH・SPCC	M3×0.5×6ℓ	ニッケルメッキ Nickel-Plated	フリータンシビス Type②
4	六角ナット Mounting plate	鉄 Steel	SWCH	M3×0.5	クロメートメッキ Chromate-Plated	

貫通型

半田付用