

3 段型端子盤

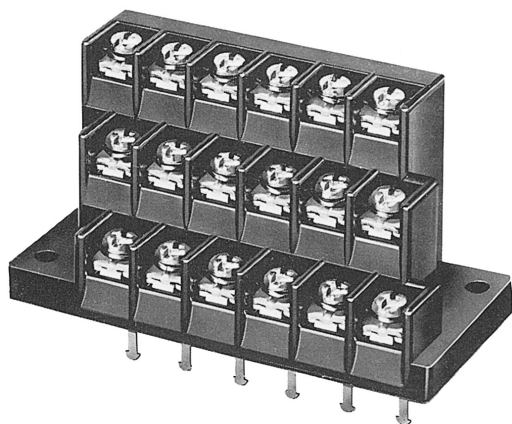

Three-stage-type Terminal Block



ピッチ/Pitch 11mm

型名 Type Number	F2034B
定格 Rating	AC250V 20A
絶縁抵抗 Insulation Resistance	500V 1000MΩ 以上 DC500V 1000MΩ and over
耐電圧 Withstands Voltage	2000V 1 分間以上 AC2000V 1 minute and over
適合電線 Compatible Wire	2.0mm ²
極数 Number of Poles	18P

一般公差/General Tolerance ±0.5

尺度/Scale ²/₃ 単位/Unit mm

3 段型

半田付用

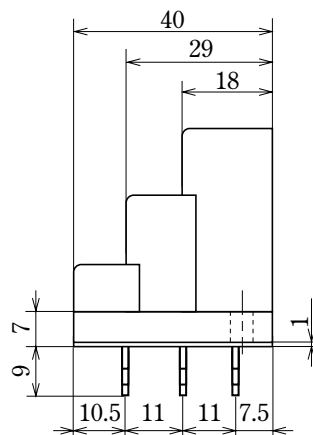
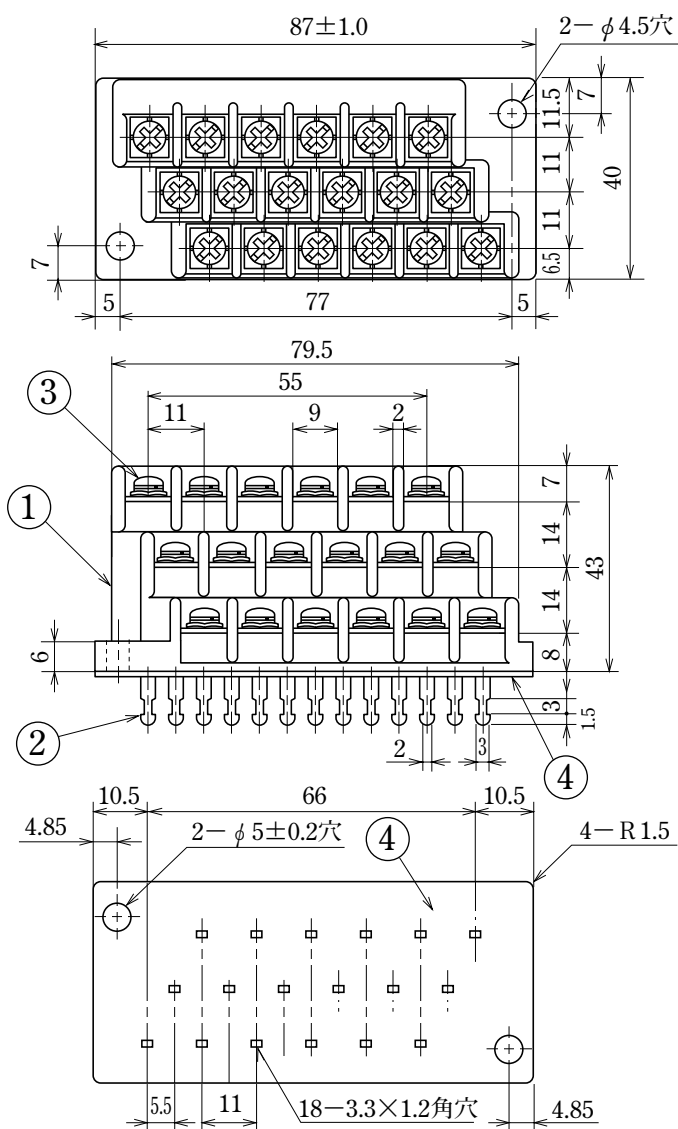

裏面ピン配置図
Pin arrangement on the rear

- 注文方法：型名 ———— 18 P.
- Ordering Form : Type No. No. of Poles (P)
- 結線ビス：締付トルクは1.4N・mです。
- Connection screw : Tightening torque is 1.4 N・m.

■仕様/Specifications.

部番/Part No.	名称/Part Name	材質/Material	規格/Standard	寸法/Size	処理/Treatment	備考/Remark
1	基板 Base	PBT	UL			黒色 Black
2	導電板 Terminal	黄銅 Brass	C2680R	板厚 t 1.0	スズメッキ Tin-Plated	
3	結線ビス Screw	鉄 Steel	SWCH・SPCC	M4×0.7×10 l	ニッケルメッキ Nickel-Plated	フリータンシビス Type①
4	裏蓋 Rear cover	積層板 Phenolic	UL			黒色 Black