

貫通型端子盤

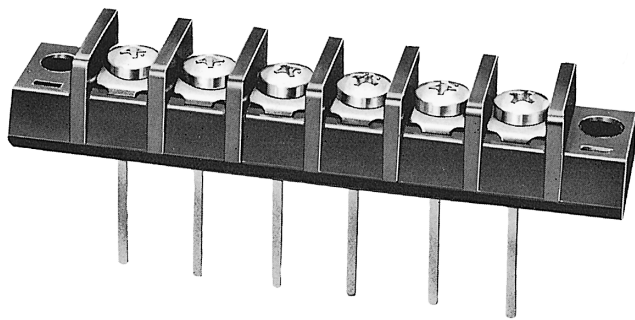

Through-type Terminal Block



ピッチ/Pitch 11mm

型名 Type Number	F2032R
定格 Rating	AC250V 15A
絶縁抵抗 Insulation Resistance	500V 100MΩ 以上 DC500V 100MΩ and over
耐電圧 Withstands Voltage	2000V 1分間以上 AC2000V 1 minute and over
適合電線 Compatible Wire	1.25mm ²

一般公差/General Tolerance ±0.5

尺度/Scale 1/1 単位/Unit mm

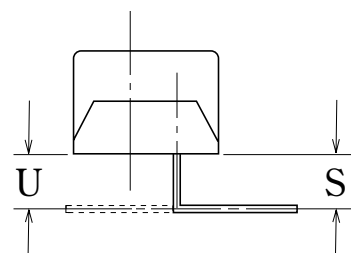
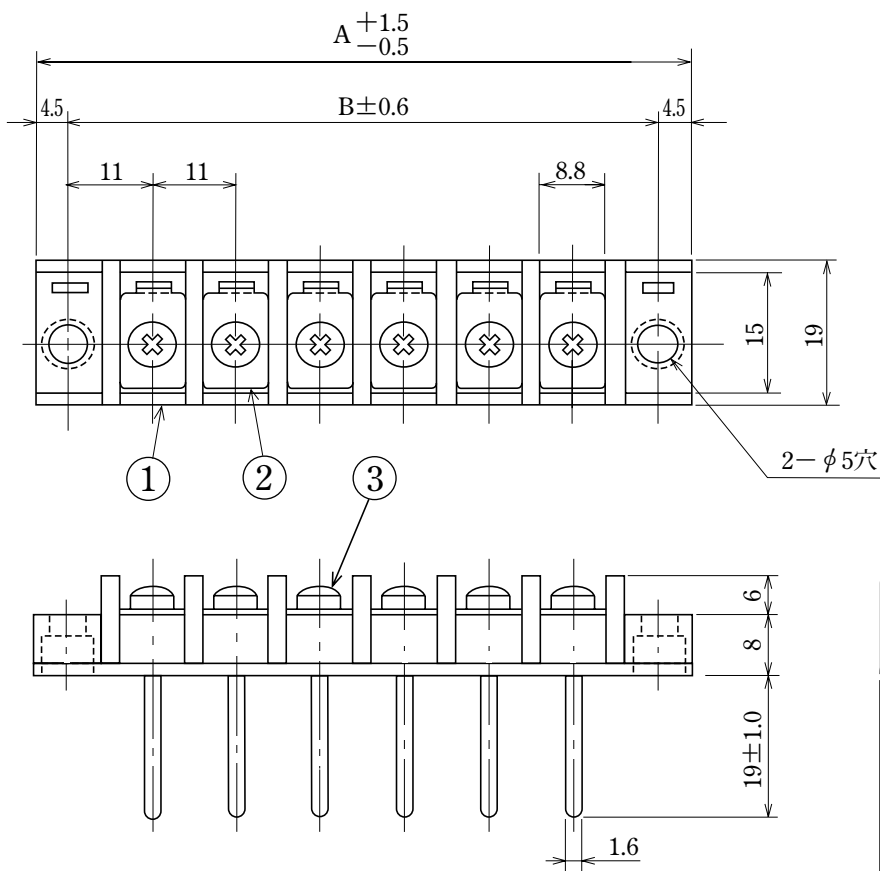

S:リード外曲げ加工例
Example of a lead bent outward.

U:リード内曲げ加工例
Example of a lead bent inward.

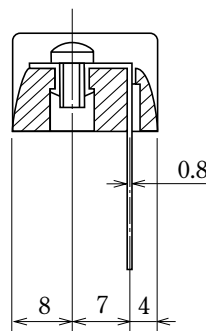

- 注文方法: 型名 (曲げ希望時) 曲げ寸法 S/U 極数 P.
- Ordering Form: Type No. Bent Length (S or U) No. of Poles (P)
(if bending is desired)
- 結線ビス: 締付トルクは1.4N・mです。
- Connection screw: Tightening torque is 1.4 N·m.

仕様/Specifications.

部番/Part No.	名称/Part Name	材質/Material	規格/Standard	寸法/Size	処理/Treatment	備考/Remark
1	基板 Base	フェノール樹脂 Phenolic	UL			黒色 Black
2	導電板 Terminal	黄銅 Brass	C2680R	板厚 t 0.8	スズメッキ Tin-Plated	
3	結線ビス Screw	黄銅 Brass	C2700W	M4×0.7×6ℓ	ニッケルメッキ Nickel-Plated	バインド Type⑧

極数/Poles	1P	2	3	4	5	6	7	8	9	10	11	12	13	14	15	16	17	18	19	20	21	22
A	31	42	53	64	75	86	97	108	119	130	141	152	163	174	185	196	207	218	229	240	251	262
B	22	33	44	55	66	77	88	99	110	121	132	143	154	165	176	187	198	209	220	231	242	253

極数/Poles	23	24
A	273	284
B	264	275

貫通型

プリント基板用