

貫通型端子盤

Through-type Terminal Block

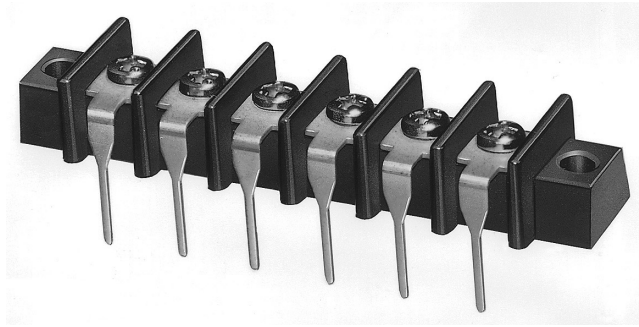

ピッチ/Pitch 10mm

型名 Type Number	F136R
定格 Rating	AC250V 6 A
絶縁抵抗 Insulation Resistance	500V 100MΩ 以上 DC500V 100MΩ and over
耐電圧 Withstands Voltage	2000V 1分間以上 AC2000V 1 minute and over
適合電線 Compatible Wire	0.5mm ²

一般公差/General Tolerance ±0.5

尺度/Scale 1/1 単位/Unit mm

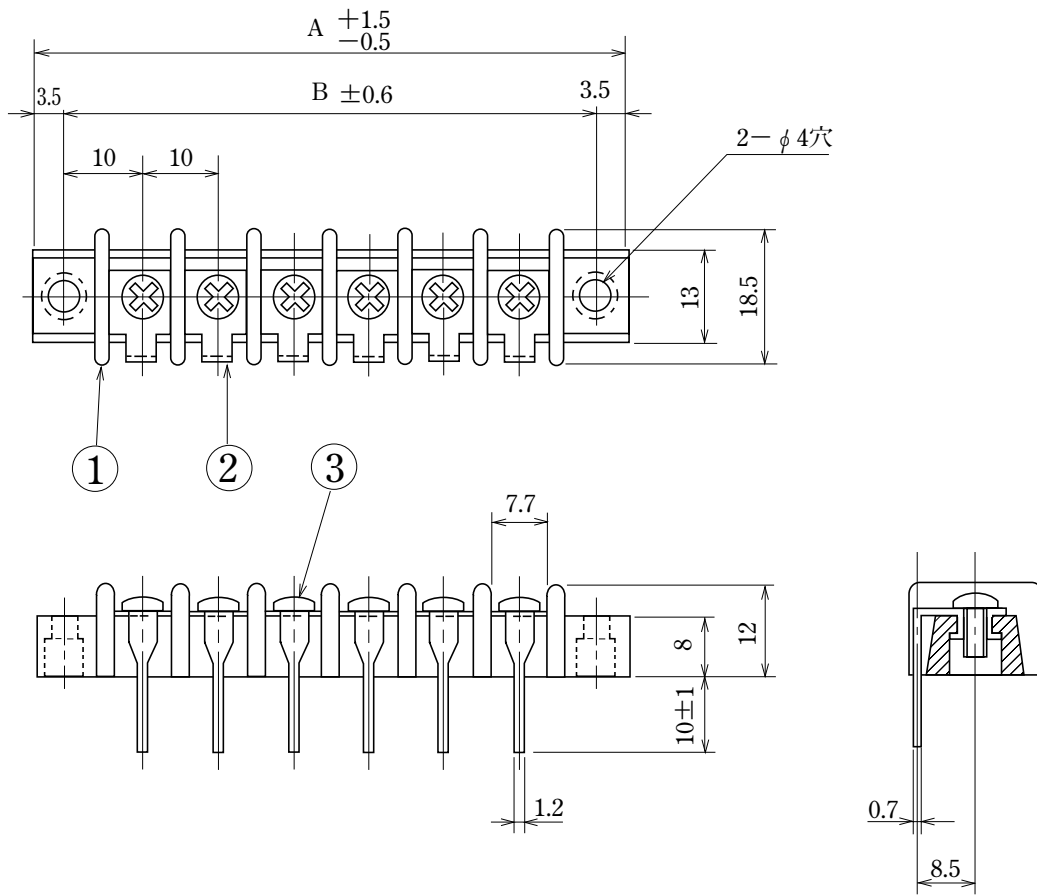

貫通型

プリント基板用

- 注文方法：型名 — 極数 P.
- Ordering Form : Type No. No. of Poles (P)
- 結線ビス：締付トルクは0.6N・mです。
- Connection screw : Tightening torque is 0.6 N・m.

■仕様/Specifications.

部番/Part No.	名称/Part Name	材質/Material	規格/Standard	寸法/Size	処理/Treatment	備考/Remark
1	基板 Base	フェノール樹脂 Phenolic	UL			黒色 Black
2	導電板 Terminal	黄銅 Brass	C2680R	板厚 t 0.7	スズメッキ Tin-Plated	
3	結線ビス Screw	黄銅 Brass	C2700W	M3×0.5×6 ℓ	ニッケルメッキ Nickel-Plated	バインド Type⑧

極数/Poles	1P	2	3	4	5	6	7	8	9	10	11	12	13	14	15	16	17	18	19	20	21	22
A	27	37	47	57	67	77	87	97	107	117	127	137	147	157	167	177	187	197	207	217	227	237
B	20	30	40	50	60	70	80	90	100	110	120	130	140	150	160	170	180	190	200	210	220	230

極数/Poles	23	24
A	247	257
B	240	250