

MULTIPIN CONNECTOR FOR REMOVABLE BATTERY

# GC/GD SERIES

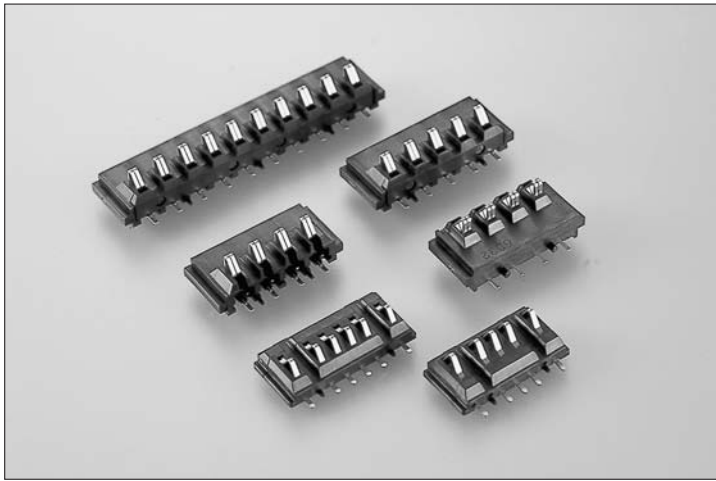



**FEATURES**

- Stroke displacement of 2.5mm for GC series and 2.3mm for GD series in a miniature connector.
- Contact cleans battery terminal every mating cycle.
- Life is 10,000 cycles for GC series and 5,000 cycles for GD series.  
(Nickel plated battery terminal is changed every 1,000 cycles)
- Highly reliable and stable contact design.
- Gold plating (0.3 $\mu$ m) for contact reliability.
- 4 variations: Standard type of 5mm pitch (GC11 series)  
Reverse type of 5mm pitch (GC02 series)  
Standard type of 3mm pitch (GD01 series)  
Reverse type of 3mm pitch (GD02 series)

**SPECIFICATIONS**

- Insulator : Glass-filled Polyamid 6T (UL 94V-0), Black
- Contact material : Copper alloy
- Contact plating :  
Contact area ; 0.3 $\mu$ m min. Gold over Nickel  
Terminal area ; 2 $\mu$ m min. Tin alloy over Nickel
- Current rating : GC series ; 5A DC per contact(2 contacts max.)  
GD series ; 5A DC per contact(2 contacts only at both ends)
- Current voltage : 30V DC
- Contact resistance : 30m $\Omega$  max.
- Dielectric withstanding voltage : 650V AC for 1 minute.
- Insulation resistance : 500M $\Omega$  min. at 500V DC
- Total contact force : GC series ; 230g  $\times$  No. of contacts max.  
GD series ; 200g  $\times$  No. of contacts max.
- Operating temperature : -55 $^{\circ}$ C to +85 $^{\circ}$ C
- \* Specification for Battery electrode : Material ; Nickel  
GC series (Finish): Nickel plating 2~4 $\mu$ m  
GD series (Finish): Gold plating 0.3 $\mu$ m min. over Nickel plating 2~4 $\mu$ m

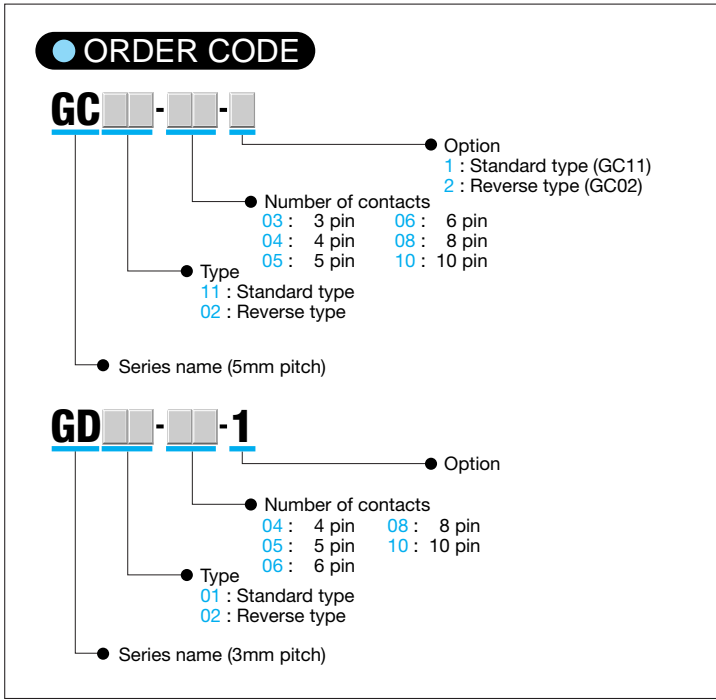

**CHARACTERISTICS** GC11-□□-1 is shown.

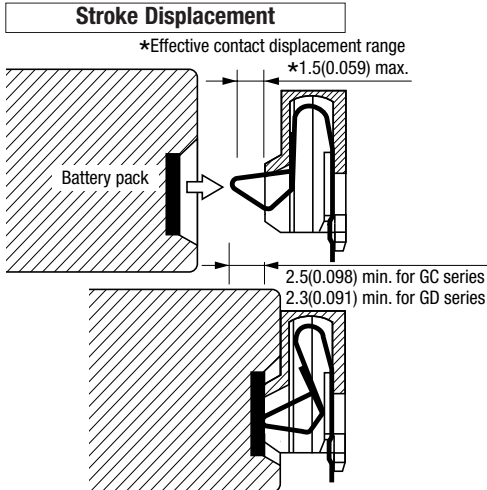

- Contact adjusts to variations in battery pack position.
- Effective contact displacement is 1.5(0.059) max.

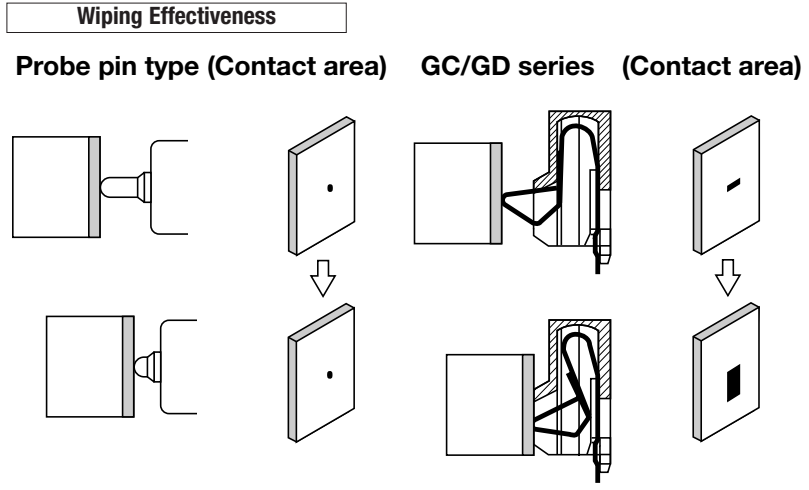

- Probe pin construction does not provide a wiping mechanism which must be provided separately. As shown above, The GC/GD series contacts wipe the battery pack terminals.

GC11-□□-1 (Standard Type)

Unit:mm(inch)

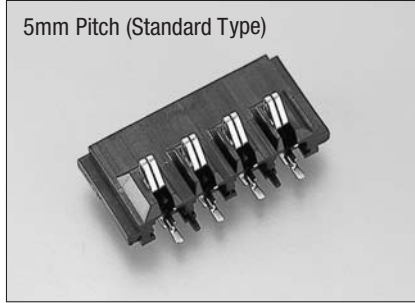

5mm Pitch (Standard Type)

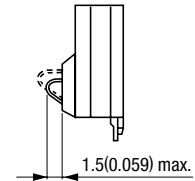
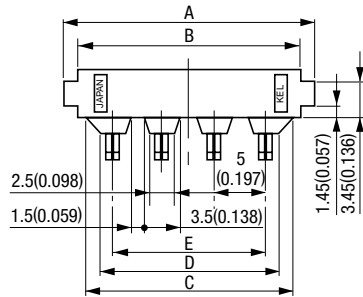

Effective contact displacement range

X-X' Cross Section

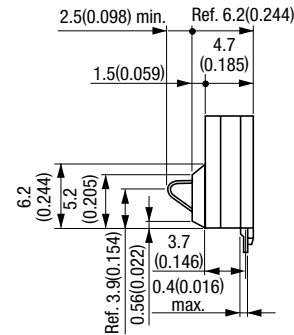
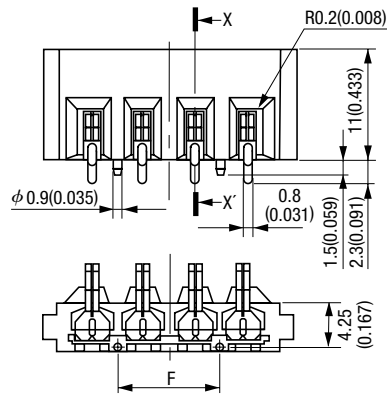
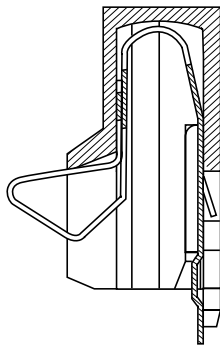

Note: 4 pin connector is shown.

Printed Circuit Board Layout  
(Component Side View)

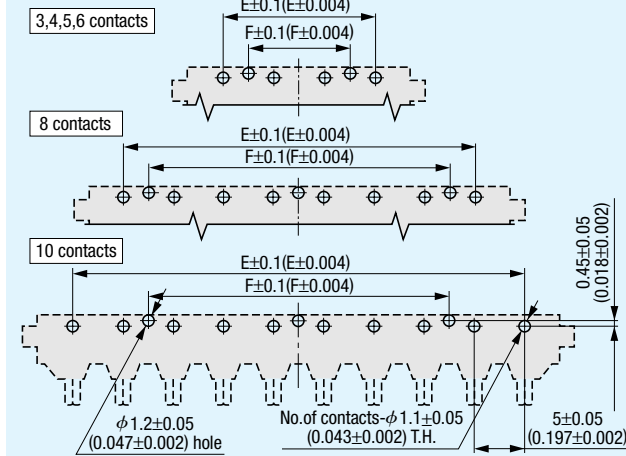

Recommended Dimensions  
for Battery Terminals

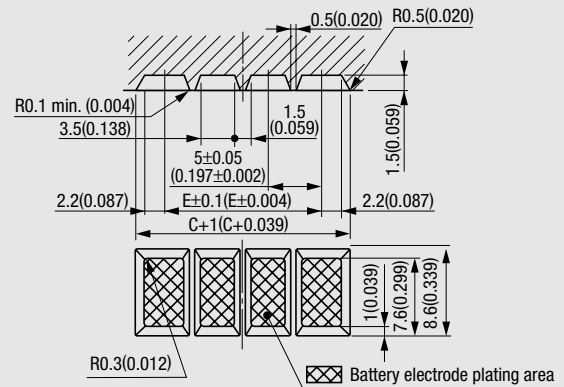

Product Table / Dimensions

No. of contacts	Part Number	A	B	C	D	E	F
3	GC11-03-1	20 (0.787)	17 (0.669)	15.6 (0.614)	13.4 (0.527)	10 (0.394)	5 (0.197)
4	GC11-04-1	25 (0.984)	22 (0.866)	20.6 (0.811)	18.4 (0.724)	15 (0.591)	10 (0.394)
5	GC11-05-1	30 (1.181)	27 (1.063)	25.6 (1.008)	23.4 (0.921)	20 (0.787)	15 (0.591)
6	GC11-06-1	35 (1.378)	32 (1.260)	30.6 (1.205)	28.4 (1.118)	25 (0.984)	20 (0.787)
8	GC11-08-1	45 (1.772)	42 (1.654)	40.6 (1.598)	38.4 (1.512)	35 (1.378)	30 (1.181)
10	GC11-10-1	55 (2.165)	52 (2.047)	50.6 (1.992)	48.4 (1.906)	45 (1.772)	30 (1.181)

**GC02-□□-2 (Reverse Type)**

Unit:mm(inch)

5mm Pitch (Reverse Type)

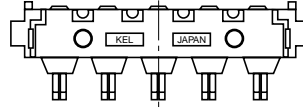
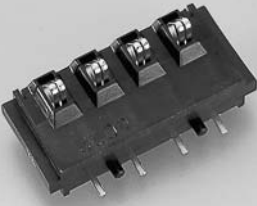

**X-X' Cross Section**

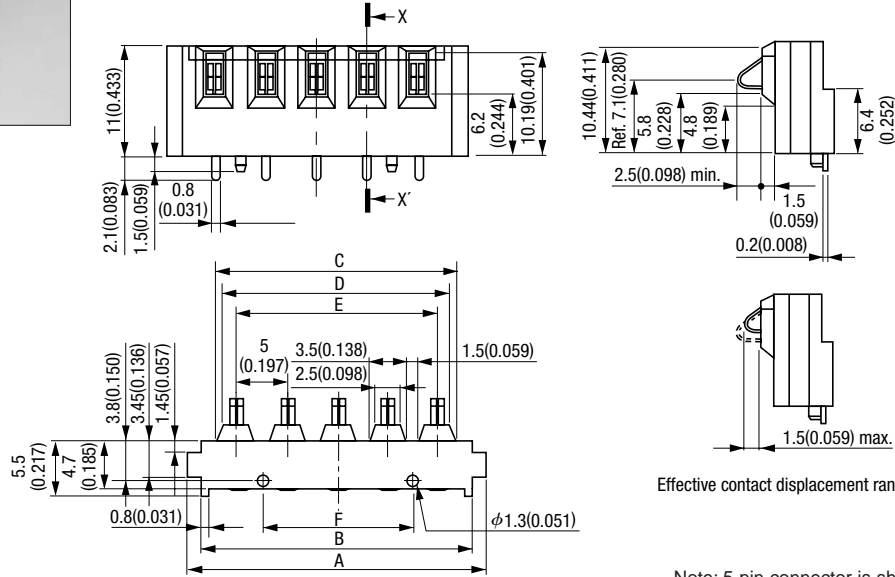
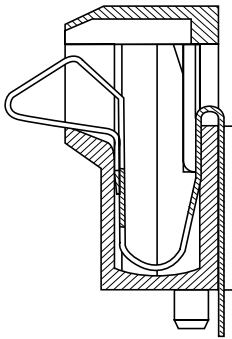

Note: 5 pin connector is shown.

**Printed Circuit Board Layout (Component Side View)**

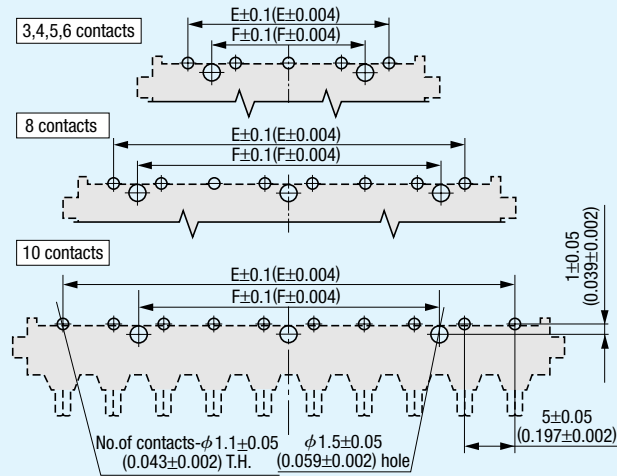

**Recommended Dimensions for Battery Terminals**

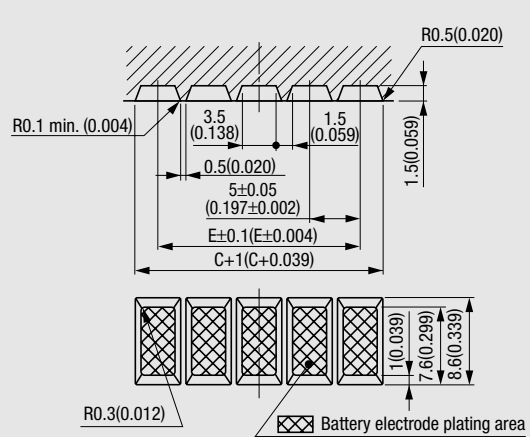

**Product Table / Dimensions**

No. of contacts	Part Number	A	B	C	D	E	F
3	GC02-03-2	20 (0.787)	17 (0.669)	13.5 (0.531)	12.5 (0.492)	10 (0.394)	5 (0.197)
4	GC02-04-2	25 (0.984)	22 (0.866)	18.5 (0.728)	17.5 (0.689)	15 (0.591)	10 (0.394)
5	GC02-05-2	30 (1.181)	27 (1.063)	23.5 (0.925)	22.5 (0.886)	20 (0.787)	15 (0.591)
6	GC02-06-2	35 (1.378)	32 (1.260)	28.5 (1.122)	27.5 (1.083)	25 (0.984)	20 (0.787)
8	GC02-08-2	45 (1.772)	42 (1.654)	38.5 (1.516)	37.5 (1.476)	35 (1.378)	30 (1.181)
10	GC02-10-2	55 (2.165)	52 (2.047)	48.5 (1.909)	47.5 (1.870)	45 (1.772)	30 (1.181)

### GD01-□□-1 (Standard Type)

Unit:mm(inch)

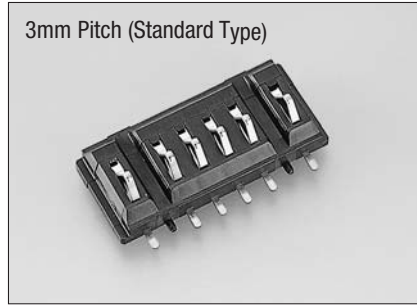

X-X' Cross Section

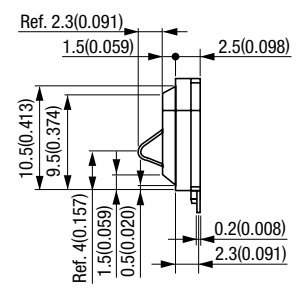
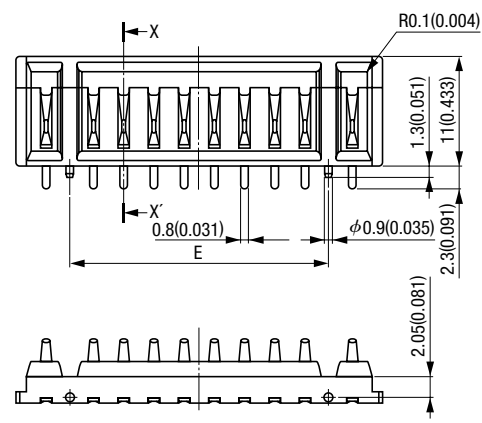
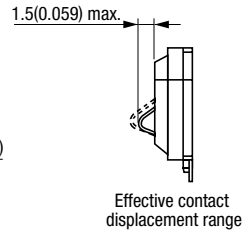
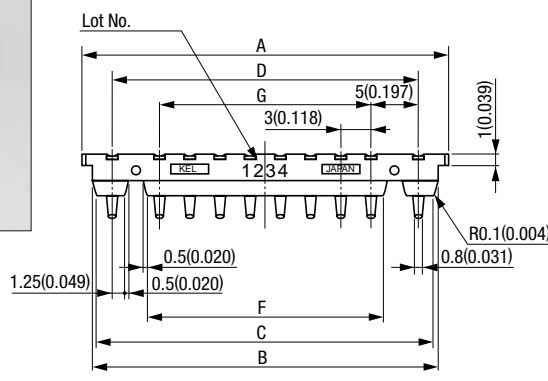
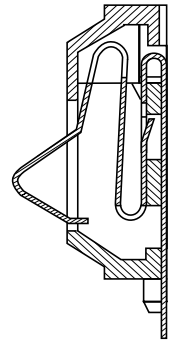

Note: 10 pin connector is shown.

#### Recommended PCB Layout (Component Side View)

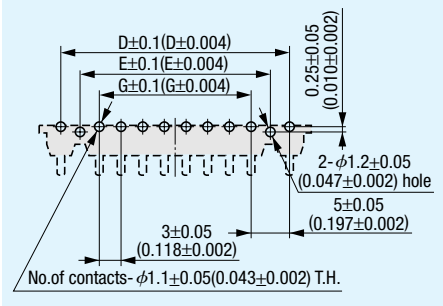

#### Recommended Dimensions for Battery Terminals

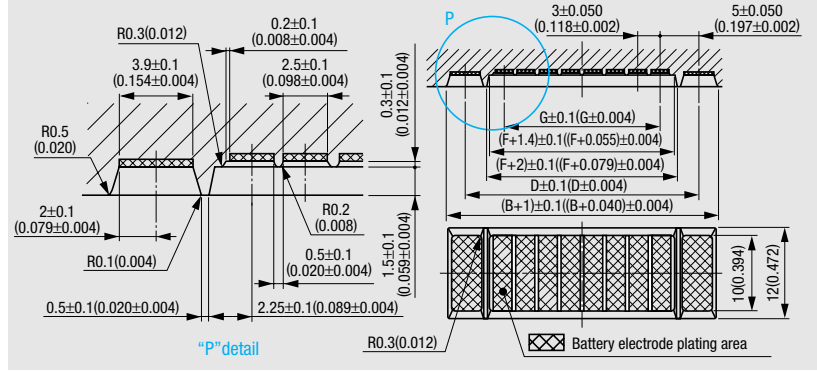

#### Product Table / Dimensions

No. of contacts	Part Number	A	B	C	D	E	F	G
4	GD01-04-1	19 (0.748)	17 (0.669)	16 (0.630)	13 (0.512)	8 (0.315)	5.5 (0.217)	3 (0.118)
5	GD01-05-1	22 (0.866)	20 (0.787)	19 (0.748)	16 (0.630)	11 (0.433)	8.5 (0.335)	6 (0.236)
6	GD01-06-1	25 (0.984)	23 (0.906)	22 (0.866)	19 (0.748)	14 (0.551)	11.5 (0.453)	9 (0.354)
8	GD01-08-1	31 (1.220)	29 (1.142)	28 (1.102)	25 (0.984)	20 (0.787)	17.5 (0.689)	15 (0.591)
10	GD01-10-1	37 (1.457)	35 (1.378)	34 (1.339)	31 (1.220)	26 (1.024)	23.5 (0.925)	21 (0.827)

**GD02-□□-1 (Reverse Type)**

Unit:mm(inch)

3mm Pitch (Reverse Type)

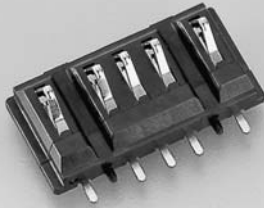

**X-X' Cross Section**

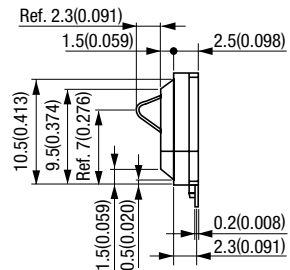
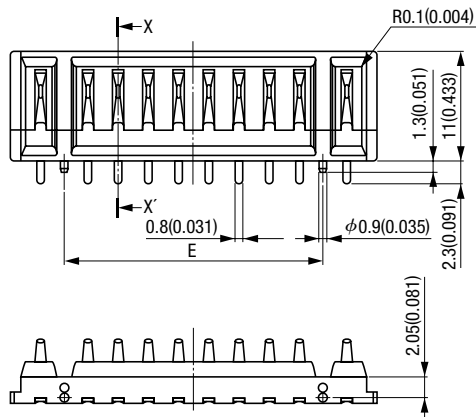
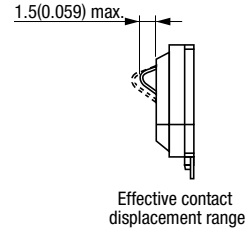
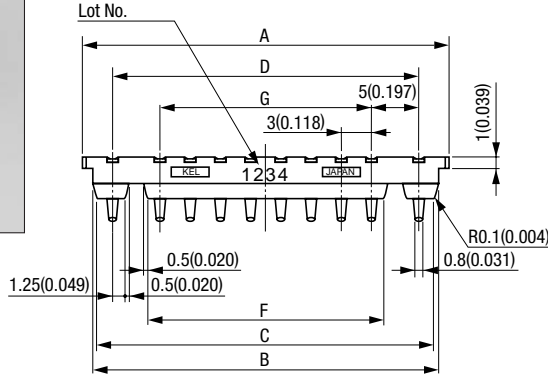
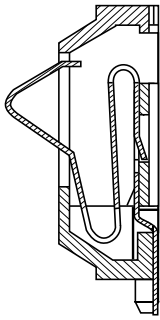

Note: 10 pin connector is shown.

**Recommended PCB Layout (Component Side View)**

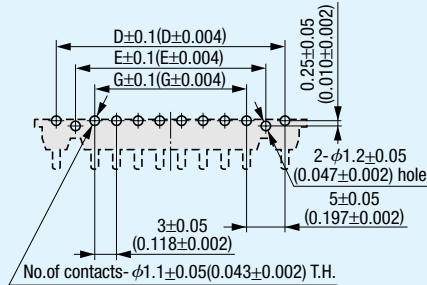

**Recommended Dimensions for Battery Terminals**

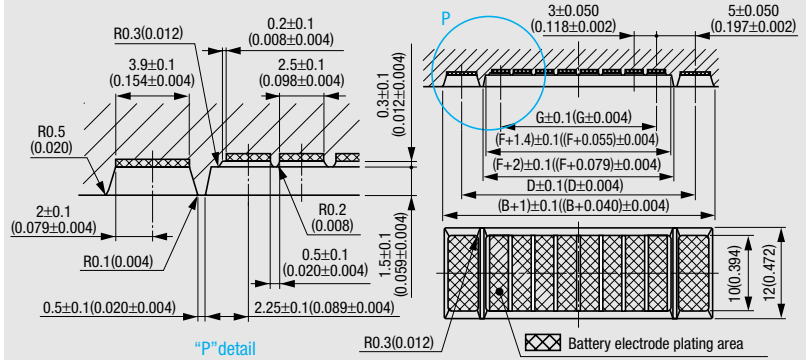

**Product Table / Dimensions**

No. of contacts	Part Number	A	B	C	D	E	F	G
4	GD02-04-1	19	17	16	13	8	5.5	3
		(0.748)	(0.669)	(0.630)	(0.512)	(0.315)	(0.217)	(0.118)
5	GD02-05-1	22	20	19	16	11	8.5	6
		(0.866)	(0.787)	(0.748)	(0.630)	(0.433)	(0.335)	(0.236)
6	GD02-06-1	25	23	22	19	14	11.5	9
		(0.984)	(0.906)	(0.866)	(0.748)	(0.551)	(0.453)	(0.354)
8	GD02-08-1	31	29	28	25	20	17.5	15
		(1.220)	(1.142)	(1.102)	(0.984)	(0.787)	(0.689)	(0.591)
10	GD02-10-1	37	35	34	31	26	23.5	21
		(1.457)	(1.378)	(1.339)	(1.220)	(1.024)	(0.925)	(0.827)

### Fixing Method

Note:

Shown below are the recommended 'Fixing Guides' to protect the PCB and Battery Connector from Stress when inserting/withdrawing the Battery pack.

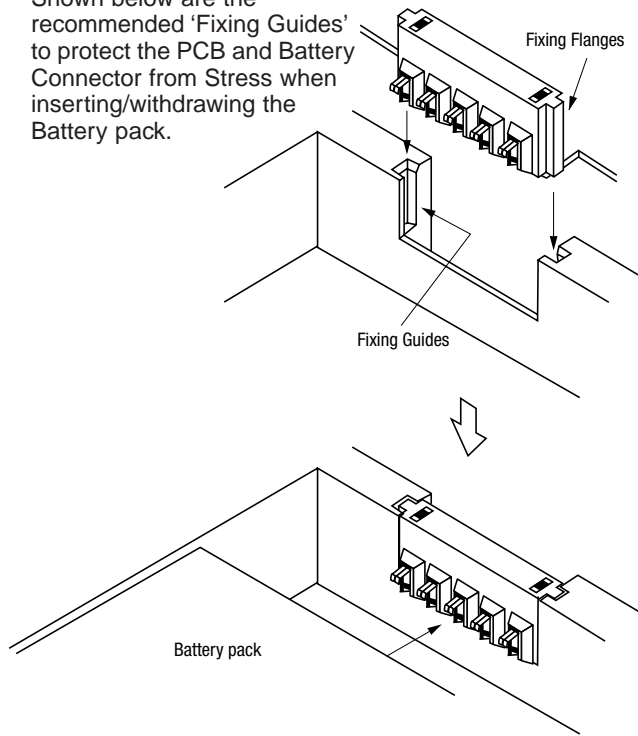

### Directions For Battery Pack Insertion/Removal

#### Horizontal

●Standard (GC11-□-□-□-1)  
(GD01-□-□-□-1)

●Reverse (GC02-□-□-□-2)  
(GD02-□-□-□-1)

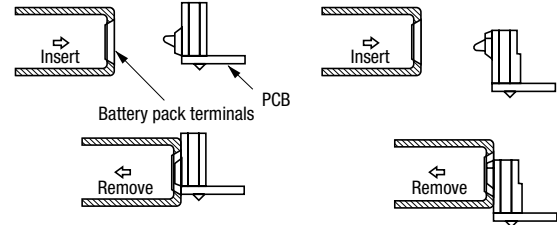

#### Vertical

●Standard (GC11-□-□-□-1)  
(GD01-□-□-□-1)

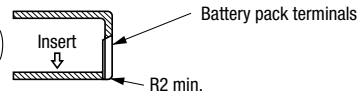

●Reverse (GC02-□-□-□-2)  
(GD02-□-□-□-1)

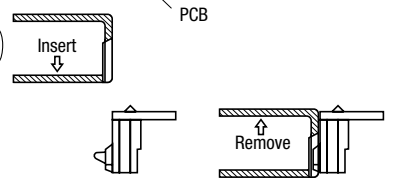

#### Acceptable range of angles

●Standard (GC11-□-□-□-1)  
(GD01-□-□-□-1)

●Reverse (GC02-□-□-□-2)  
(GD02-□-□-□-1)



Note:

Please keep your design within the prescribed acceptable range of angles for battery pack insertion/removal, otherwise battery pack or connector will be damaged.

Short-circuit Contact



### FEATURES

- Low profile (0.45mm)
- Life is 10,000 cycles
- Gold plating (0.3 $\mu$ m) for contact reliability
- Easy hand mounting without tooling
- Can improve safety of the battery pack

### SPECIFICATIONS

- Contact material: Copper alloy
- Plating (Contact area) : 0.3 $\mu$ m min. Gold over Nickel
- Current rating : DC 3A
- Contact resistance : 30m $\Omega$  max.
- Contact force : 1kg max.
- Operating temperature : -55 $^{\circ}$ C to +85 $^{\circ}$ C
- \* Specification for Battery electrode : Material ; Nickel

### ORDER CODE

**064G**

- Plating of contact area  
G : Au 0.3 $\mu$ m (Standard)
- Series name  
Short-circuit contact for battery pack

## 064G

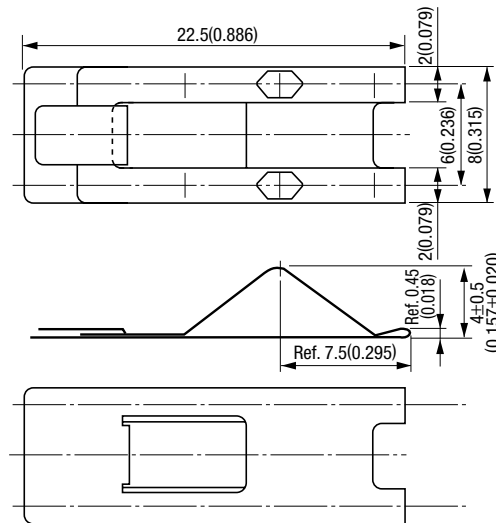

Unit:mm(inch)

### Recommended Assembly Procedure

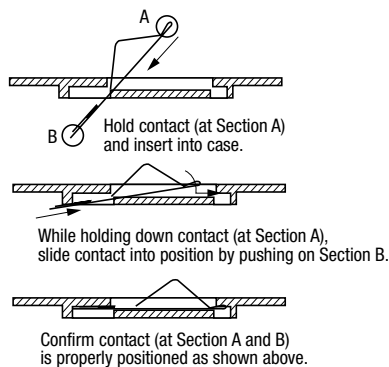

### Recommended Panel Layout

